

ENGINEERING DRAWING AND GRAPHICS



Government College of Engineering & Ceramic Technology

73, A.C. Banerjee Lane

Kolkata-700010

Govt. of West Bengal

Introduction to Engineering Drawing

Drawing is the graphical means of expression of ideas, thoughts and feelings without the barrier of a language. Engineering Drawing is the Universal Language for Engineers. Communication in engineering is necessary for effectively transferring one's ideas to others. While communicating, we use our memory to remember objects, sense organs to perceive objects and mind to imagine objects. Our perception are coloured or modified by our past experiences.

We see things around us, perceive the objects and identify them by their names. Later, when we hear these names we can remember these items easily and imagine various features like the shape, size, color, functions etc, e.g. if I say that a particular object is having the shape of a cricket bat, it is easy for a high school student to imagine the shape of the object since he has seen a cricket bat and has perceived the object. If I say that a particular object looks like the Dendrite formed during solidification of a metal, then it is difficult for the same student to imagine, since he has not seen a dendrite. His question will “how do a dendrite look like?” when we say that dendrite means tree-like structure, his imagination can go to different types of trees, but still he may not have a clear picture of the dendrite. If we show him a picture of a dendrite, he can very easily perceive that object.

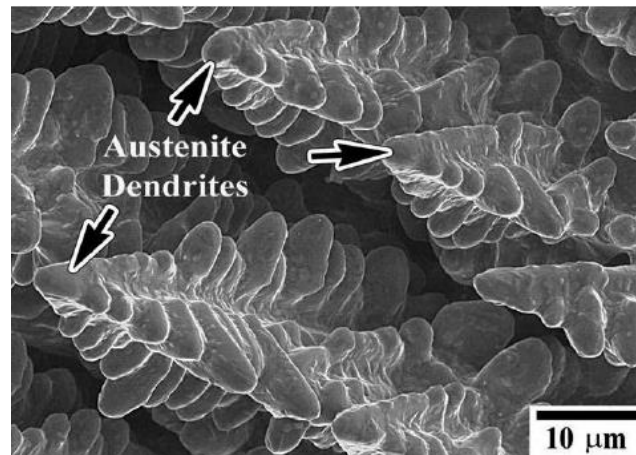

Primary austenite dendrites during solidification of a high-Cr iron before the eutectic reaction takes place.

One picture/drawing is equivalent to several sentences. It is not easy for anyone to make another person understand somebody's face just by explaining the features. Even if several sentences are

used to explain the features of the face, words it would be difficult for the listener to perceive the image of the face. However, if you show a sketch or a photograph of the person, all these sentences can be saved. i.e., We grasp information easily if it is illustrated with diagrams, sketches, pictures, etc.

Engineering drawing

Drawings help us in developing our thoughts and ideas into a final product. It is a marvelous medium of expression, a powerful language. It does not change its complexion like spoken languages with the crossing of the boundary of a country. The practice and implementation is more or less the same all over the globe.

It may also be noteworthy to mention that the drawing of a space-shuttle or Hooghly bridge or Tajmahal is no less beautiful than the artwork of a great master artist. Therefore the students should try to master this subject right from the beginning since it has far-reaching effects in their post-educational professional practice.

This subject distinguishes an engineer from a basic scientist who lacks a formal training in this subject.

What information should be available in an engineering drawing?

A perfect engineering drawing should have the following information:

- Shape of an object
- Exact Sizes and tolerances of various parts of the object
- The finish of the product
- The details of materials
- The company's name
- Catalogue no of the product
- Date on which the drawing was made
- The person who made the drawing

Drawings are the road maps which show how to manufacture products and structures. No industrial level construction/manufacturing of any (man-made) engineering objects is possible without engineering drawing.

What will you learn from this course?

In this course you will learn how to communicate technical information by:

Visualization – the ability to mentally understand visual information

Graphics theory – geometry and projection techniques used for preparation of drawings

Use of standards – set of rules for preparation of technical drawings

Use of conventions – commonly accepted practices in technical drawings

Tools – devices used to create technical drawings and models

Applications – the various uses for technical drawings

Developing an engineering drawing can be either by manual drawing or by computer graphics. Computer has a major impact on the methods used to design and create technical drawings. The tools are Computer aided design and drafting (CADD). Design and drafting on computer are cheap and less time consuming. Then why we go for manual drawing?

Computer cannot replace the drafting board and equipment as a learning tool. In schools, students are not allowed to use calculators up to class 12. During this period if they use calculators from class 1, they will not improve their mathematical skills. After class 12, i.e., once they have learned the basics of mathematics, they are allowed to use calculators and computers. Hence before use of the drafting software, their fundamentals regarding drawing should be clear. If basic fundamentals are clear, better use can be made of the power of the software. To be an expert in technical drawing, this first course on Engineering (manual) drawing is the first step.

DRAWING INSTRUMENTS AND ACCESSORIES

The following set of instruments is required for ensuring good quality manual drawing:

Drawing board

Drawing board is made of soft well-seasoned wood. Almost perfect planing of the working surface of the drawing board is to be ensured. A strip of hard ebony edge is fitted up in a groove on the shorter edge of the board and perfectly lined to provide the guide for the T-square. The standard sizes of the drawing board are shown in Table 1.1 below.

Table 1.1: Standard dimensions of Drawing Board

Designation	Length X Width (mm)	Recommended for use with sheet sizes
D0	1500 X 1000	A0
D1	1000 X 700	A1
D2	700 X 500	A2
D3	500 X 350	A3

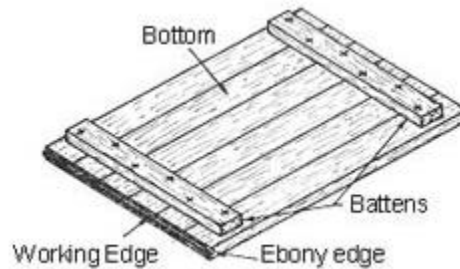

Drawing Sheet

Drawing sheet is the medium on which drawings are prepared by means of pencils. Drawing sheets are available in standard sizes as shown in Table 1.2. A standard A0 size sheet is the one with an area of 1 m^2 and having dimensions of 1189 x 841. Each higher number sheet (A1, A2, A3, etc. in order) is half the size of the immediately lower numbered sheet. For drawing practice for first year engineering students A1 size is the preferred drawing sheet. The recommended sizes obtained for various drawing sheets are shown in figure.

Table 1.2 Standard sizes of drawing sheets as per BIS

Designation	Size (mm)
A0	1189 X 841
A1	841 X 594
A2	594 X 420
A3	420 X 297
A4	297 X 210

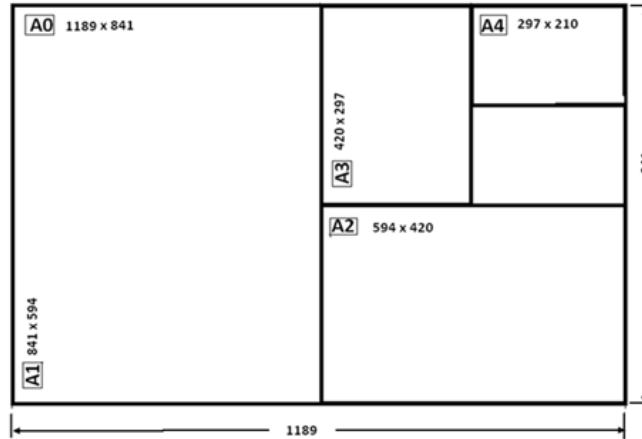

Recommended sizes obtained for various drawing sheets

T-Square:

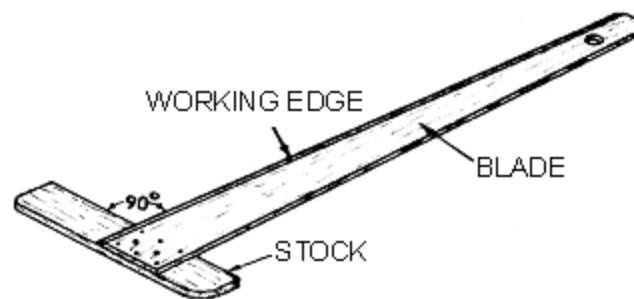

It consists of two parts- the stock and the blade-joined together at right angle. The stock is placed adjoining the working edge of the board and is made to slide on it as and when required. The T-square is used for drawing horizontal lines.

Mini-drafter

This is a device used to draw parallel or inclined lines very effectively with ease. This is mounted on the top left corner of the drawing board by means of a clamping mechanism which is an integral part of the device. Figure 2 shows the photograph of a typical college level mini drafter. An L-shaped scale which is graduated in millimeters acts as the working edge of the mini-drafter. The L-Shaped scale also has a degree scale for angle measurement. The working edge can be moved to any desired location on the drawing board.

Procedure for clamping the mini-drafter

Set the protractor head with reference mark indexing zero degree, then fix the clamp of the mini-drafter at the top left corner either along the top horizontal edge of the board or along the left vertical edge of the board. With the drawing sheet placed underneath the scales of the mini-drafter, fix the drawing sheet to the drawing board with the scales of the mini-drafter aligned either with the vertical or the horizontal borderlines of the drawing sheet.

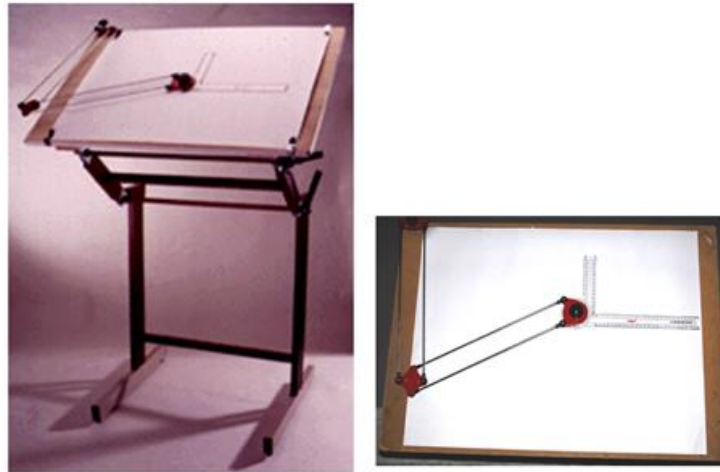

Figure 2. Photograph of a typical college level drawing table, drawing board and mini-drafter assembly

Set squares

Set squares are a set of 45° set square and 30° - 60° set-square, as shown in figure 3. They are used in conjunction with each other and with T-square to draw parallel, inclined and perpendicular lines. They are made of transparent acrylic. Each is having beveled edges with engraved mm or inch marking.

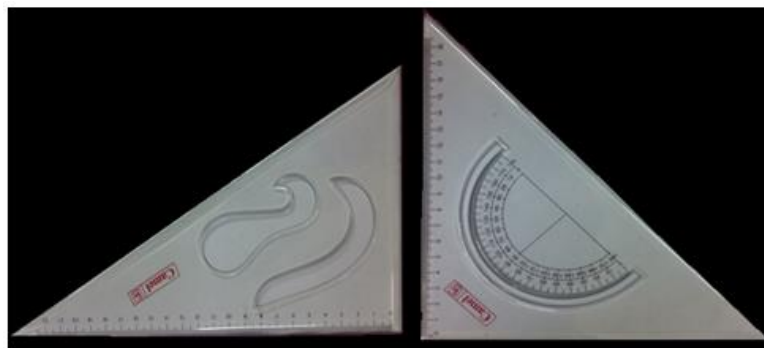

Figure 3. Set Square set

Compasses

Partha Haldar, Assistant Professor, Mechanical Engineering, GCECT, Kolkata-10.

These are used to draw arcs or circles. For drawing very large radius arcs, the pencil point leg can be removed from the knee joint and a lengthening bar can be inserted to increase the radius of the arc. Figure 4 shows the photograph of a compass.



Figure 4. Photograph of a compass

Divider

Dividers are used to transfer lengths to the drawings either from scales or from the drawing itself. Similar to the compasses, two sizes of dividers are used in technical drawings. One large divider and the other small spring bow divider.



Pencils / lead sticks/ pencil sharpener / eraser/etc.:

The primary tool used in technical drawings is the pencil or lead sticks. Generally for technical drawings, the three grades of pencil used is H (for main drawing) and 2H (for construction lines). For different purposes, different grades of pencils are used. Pencil sharpener is used to mend the pencils. Eraser is used to erase the unnecessary part of the pencil drawing.

French curve/Flexible curve

French curve is free form template made of acrylic and is used to draw a smooth curve passing through a number of points. The outer profile of the French curve is adjusted such the smooth curve passes through **more than three points** and a curve passing through these lines are drawn. The next part of the curve is then drawn by using the next three points in addition to the last two points of the previous curve. A typical French curve is shown in figure.



A typical French Curve

Layout of drawing sheets

Any engineering drawing has to follow a standard format. The drawing sheet consist of drawing space, title block and sufficient margins. After fixing the drawing sheet on the drawing board, margins should be drawn. The layout should facilitate quick reading of important particulars. Drawings are prepared at various locations and shared and quick references should be located easily.

A typical drawing sheet is shown in figure 4 and consist of the following:

- a. Borders – space left all around in between the trimmed edges of the sheet.
- b. Filling margin – 20 mm minimum on left hand side with border included. This is provided for taking perforations.
- c. Grid reference system – For all sizes of drawing sheets for easy location of drawing within the frame. The length and the width of the frames are divided into even number of divisions. Number of divisions for a particular sheet depends on complexity of the drawing. The length of the grids lies between 25 mm to 75mm depending on the Drawing sheet size. The grids along vertical edges are named by capital letters where as grids along the horizontal edges are by numerals. Numbering and lettering start from the corner of the sheet opposite to the title box and

are repeated on the opposite sides. The numbers and letters are written upright. Repetition of letters or numbers like AA, BB, etc. are practiced in case they exceed that of the alphabets.

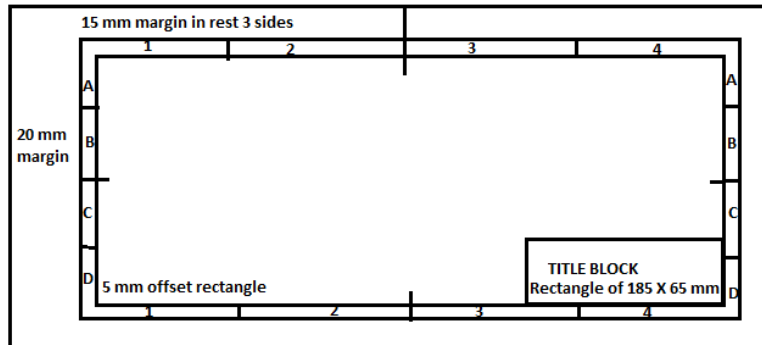
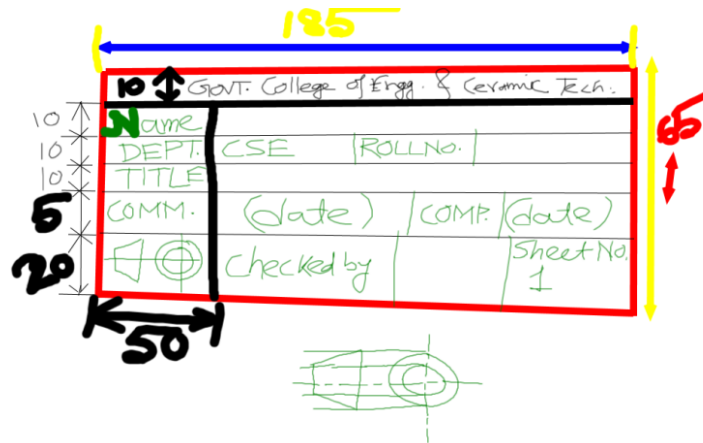

Figure 7. Typical drawing layout showing the margins, location of title block and grids.







- d. **Title box** – An important feature which is a must in every drawing sheet. The title box is drawn at the bottom right hand corner of every drawing sheet and provides technical and administrative details regarding the drawing/component.

Details about title block



Lines

Lines is one important aspect of technical drawing. Lines are always used to construct meaningful drawings. Various types of lines are used to construct drawing, each line used in some specific sense. Lines are drawn following standard conventions mentioned in BIS (SP46:2003). A line may be curved, straight, continuous, segmented. It may be drawn as thin or thick.

Illustration	Application
Thick 	Outlines, visible edges, surface boundaries of objects, margin lines
Continuous thin 	Dimension lines, extension lines, section lines leader or pointer lines, construction lines, boarder lines
Continuous thin wavy 	Short break lines or irregular boundary lines – drawn freehand
Continuous thin with zig-zag 	Long break lines
Short dashes, gap 1, length 3 mm 	Invisible or interior surfaces
Short dashes 	Center lines, locus lines Alternate long and short dashes in a proportion of 6:1,
Long chain thick at end and thin elsewhere 	Cutting plane lines

Conventions used in lines

- Millimeter (mm) - The common SI unit of measure on engineering drawing.
- Individual identification of linear units is not required if all dimensions on a drawing are in the same unit (mm).
- The drawing should contain a note: ALL DIMENSIONS ARE IN MM. (Bottom left corner outside the title box)

Dimensioning

The size and other details of the object essential for its construction and function are required to be indicated in a drawing by proper dimensioning.

The dimensions are written either above the dimension lines or inserted at the middle by breaking the dimension lines.

Normally two types of dimensioning system exist. i.e. Aligned system and the unidirectional system. These are shown in figure.

Aligned system: Dimensions may be read from the bottom edge or the right hand edge of the drawing sheet.

Unidirectional system: Dimensions can be read from the bottom edge of the drawing sheet.

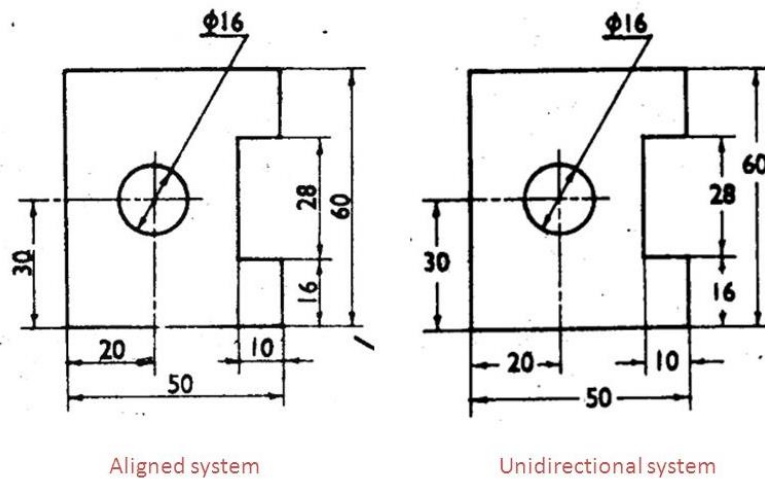

The aligned system and unidirectional system of dimensioning.

Rules to be followed for dimensioning.

- All the dimensions on a drawing must be shown using either Aligned System or Unidirectional System. In no case should, the two systems be mixed on the same drawing.
- Dimensioning should be done so completely that further calculation or assumption of any dimension is not necessary.
- Every dimension must be given but should not be given more than once.
- Mutual crossing of dimension lines are not allowed.
- As far as possible, all the dimensions should be placed outside the views. Inside dimensions are preferred only if they are clearer and more easily readable.
- The same unit of length should be used for all the dimensions on a drawing. The unit should not be written after each dimension, but a note mentioning the unit should be placed below the drawing.
- A thin, solid line that shows the extent and direction of a dimension. Dimension lines are broken for insertion of the dimension numbers
- Should be placed at least 10 mm away from the outline and all
- other parallel dimensions should be at least 6 mm apart, or more, if space permits

The important elements of dimensioning consist of extension lines, leader line, arrows and dimensions.

Partha Halder, Assistant Professor, Mechanical Engineering, GCECT, Kolkata-10.

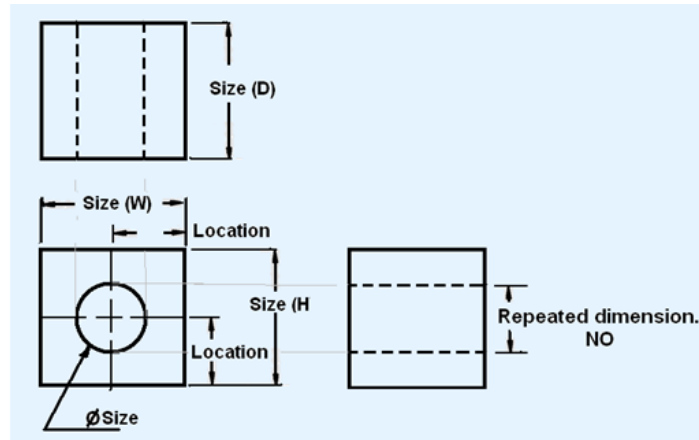

Typical dimension lines

Dimensioning consists of the following:

Extension line – a thin, solid line perpendicular to a dimension line, indicating which feature is associated with the dimension. There should be a visible gap of 1.5 mm between the feature’s corners and the end of the extension line. Figure 5 shows extension lines.

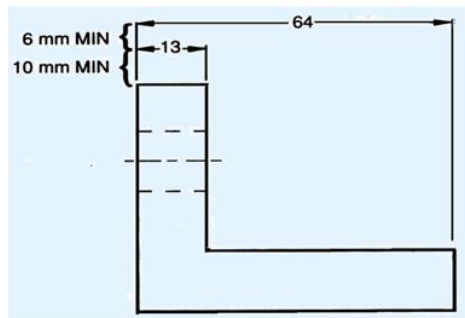

Figure showing extension lines

Leader line

A thin, solid line used to indicate the feature with which a dimension, note, or symbol is associated. Generally this is a straight line drawn at an angle that is neither horizontal nor vertical. Leader line is terminated with an arrow touching the part or detail. On the end opposite Partha Halder, Assistant Professor, Mechanical Engineering, GCECT, Kolkata-10.

the arrow, the leader line will have a short, horizontal shoulder. Text is extended from this shoulder such that the text height is centered with the shoulder line

- Arrows – 3 mm wide and should be 1/3rd as wide as they are long - symbols placed at the end of dimension lines to show the limits of the dimension. Arrows are uniform in size and style, regardless of the size of the drawing. Various types of arrows used for dimensioning is shown in figure.

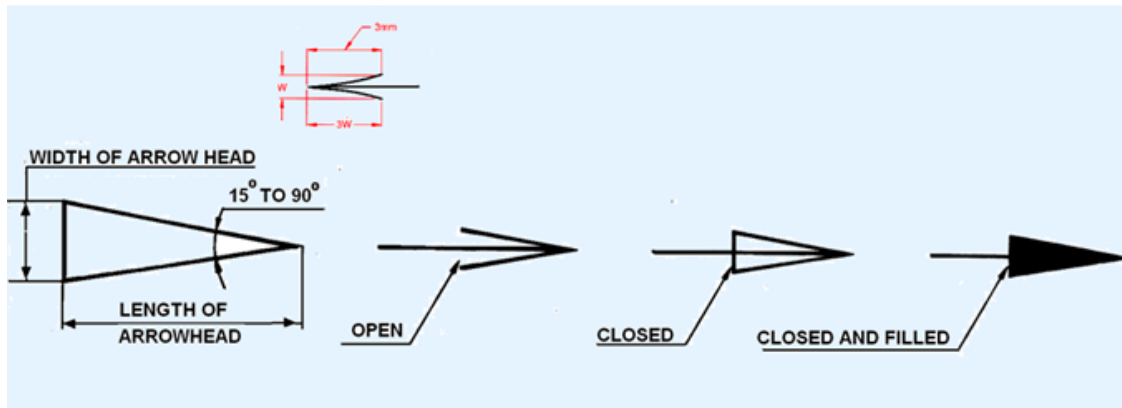

Various types of arrows used for dimensioning

Dimensioning of angles: The normal convention for dimensioning of angles are illustrated in figure.

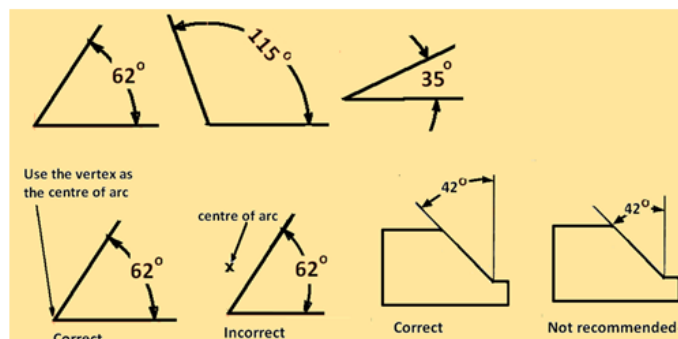

Conventions used for dimensioning angles.

RULES OF DIMENSIONING

1. For dimensions in series, adopt any one of the following ways.

- i. Chain dimensioning (Continuous dimensioning): All the dimensions are aligned in such a way that an arrowhead of one dimension touches tip-to-tip the arrowhead of the adjacent dimension. The overall dimension is placed outside the other smaller dimensions.
- ii. Parallel dimensioning (Progressive dimensioning) All the dimensions are shown from a common reference line. Obviously, all these dimensions share a common extension line. This method is adopted when dimensions have to be established from a particular datum surface

Scale:

There is a wide variation in sizes for engineering objects. Some are very large (Aero planes, rockets, etc.) Some are very small (wrist watch, electronics components)

There is a need to reduce or enlarge while drawing the objects on paper. Some objects can be drawn to their actual size. The proportion by which the drawing of an object is enlarged or reduced is called the scale of the drawing.

A scale is defined as the ratio of the linear dimensions of element of the object as represented in a drawing to the actual dimensions of the same element of the object itself.

- Drawings drawn with the same size as the objects are called **full sized** drawing.
- It is not convenient, always, to draw drawings of the object to its actual size. e.g. Buildings, Heavy machines, Bridges etc. (**Reduced** Size drawing) and Watches, Electronic devices etc.(**Enlarged** size drawing)

BIS Recommended Scales

Reducing scales 1:Y (Y>1)	1:2 1:20 1:200 1:2000	1:5 1:50 1:500 1:5000	1:10 1:100 1:1000 1:10000
Enlarging scales X:1 (X>1)	50:1 5:1	20:1 2:1	10:1
Full size scales			1:1

Representative fraction (R.F.):-

$$\text{R.F.} = \frac{\text{Length of an object on the drawing}}{\text{Actual Length of the object}}$$

When a 1 cm long line in a drawing represents 1 meter length of the object

$$R.F = \frac{1\text{cm}}{1\text{m}} = \frac{1\text{cm}}{1 \times 100\text{cm}} = \frac{1}{100}$$

Length of scale = RF x Maximum distance to be represented

Sheet 1: **Lines, Lettering, Dimensioning and Scale:**

1. Different types of lines and dimensions

Fig. 3-2 of N. D Bhat

2. Lettering and numbering
3. Construct a plain scale where 1 cm represents 4 meters. The scale is long enough to measure a distance 50 m. Find its R.F. Show distance 37 meter on the scale.

Solution:

$$R.F = \frac{1\text{ cm}}{4\text{ m}} = \frac{1}{400}$$

$$\text{length of the scale} = \frac{1}{400} \times 50 \times 100 = 12.5\text{ cm}$$

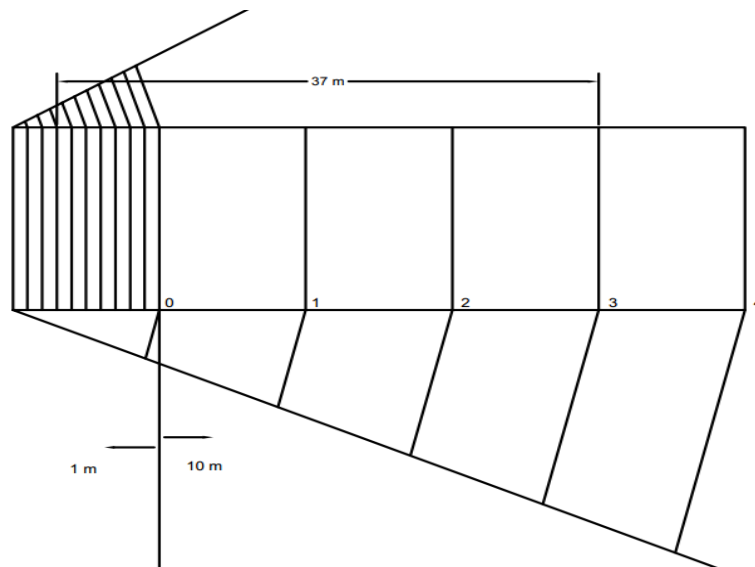

4. The distance between Delhi and Agra is 200 km in a railway map. It is represented by a line 5 cm long. Find its R.F. Draw a diagonal scale to show a single km and maximum 600 km. indicate 459 km on the scale.

Sheet 2: Engineering Curves:

1. Draw a regular hexagon of side 45 mm
2. Inscribe a pentagon in a circle of diameter 60 mm.
3. The major axis of an ellipse is 150 mm long and minor axis is 100 mm long. Draw an ellipse by using concentric circle method.
4. Draw a rectangle having its sides 125 mm and 75 mm long. Inscribe a parabola in it.
5. P is 30 mm and 50 mm far from two straight lines at right to each other. Draw a rectangular hyperbola through point P within 10 mm distance from each other.
6. Draw an involute of a circle of 40 mm.
7. A circle of 50 mm diameter rolls along the straight line without slipping. Draw a curve traced out by a point P from the circumference for 1 complete revolution of circle. Name the curve.

Orthographic Projection and projections of points

Four quadrants:

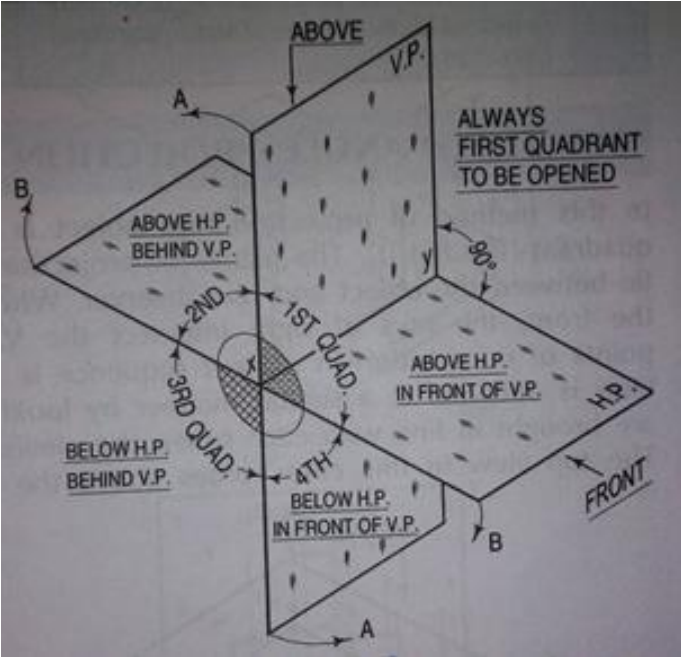

First angle Projection

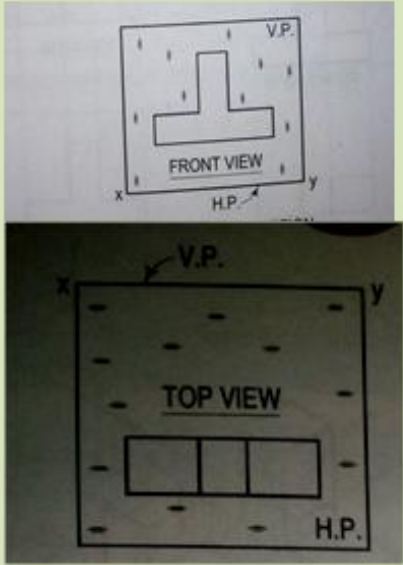
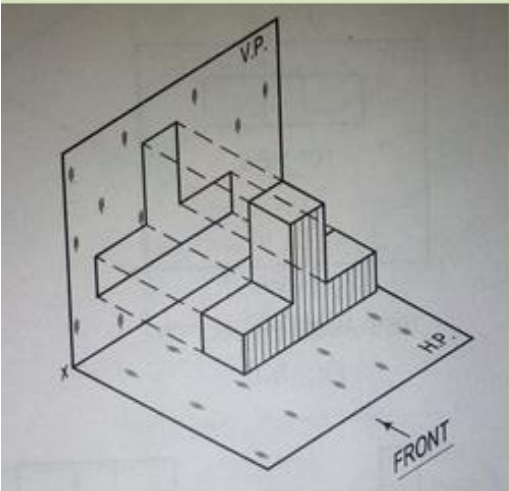

First angle Projection

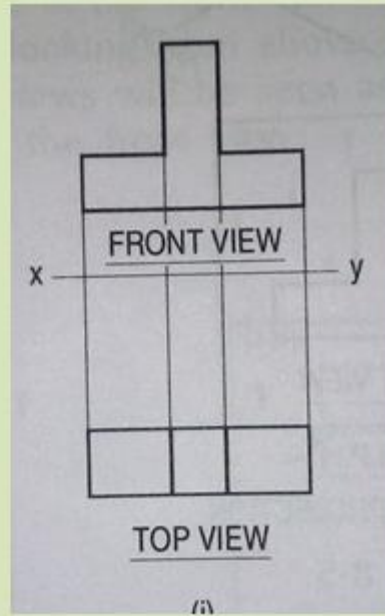
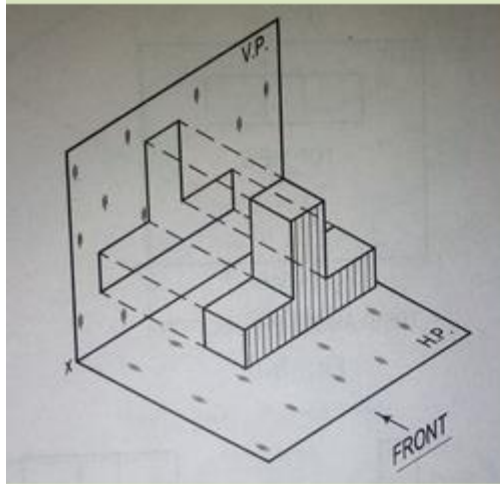

Third Angle Projection

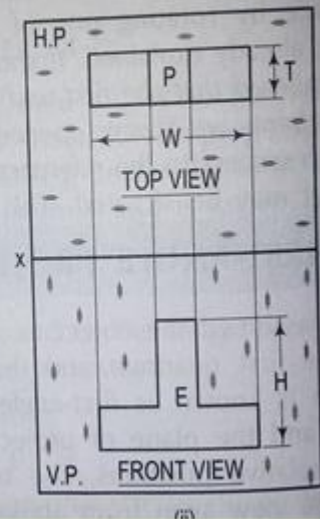
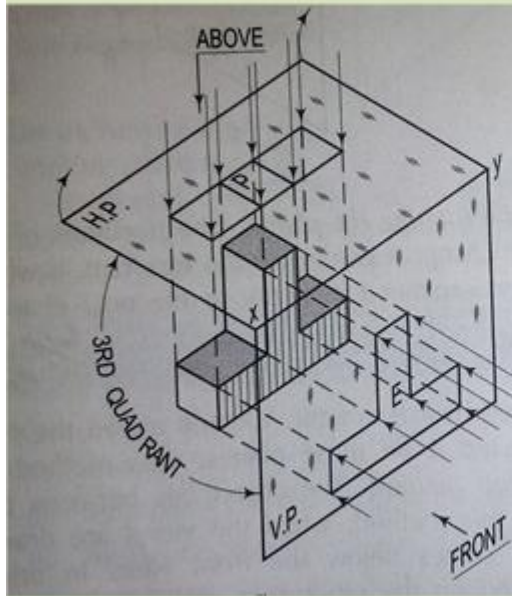

1 st Angle Projection	3 rd Angle Projection
Object Lies between the observer and plane of projection	The plane of projection lies between the observer and the object
Plane of projection is assumed to be non-transparent	Plane of projection is assumed to be transparent
Plan comes below the elevation	Plan comes above the elevation
Recommended by BIS since 1991	Recommended by USA

BIS Code for Practice

- Formerly in India 1st angle projection was used.
- From 1955 3rd angle projection.
- In December 1973 onwards, option was opened between 1st and 3rd angle projection.
- 1988 onwards 1st angle finalized.

Sign Convention

- Actual points, Ends of lines, corners of solids denoted by A, B, C etc.
- Top views by a, b, c etc
- Front views by a', b', c' etc.
- Side views by a₁, b₁, c₁ etc.

Symbols for method of projection

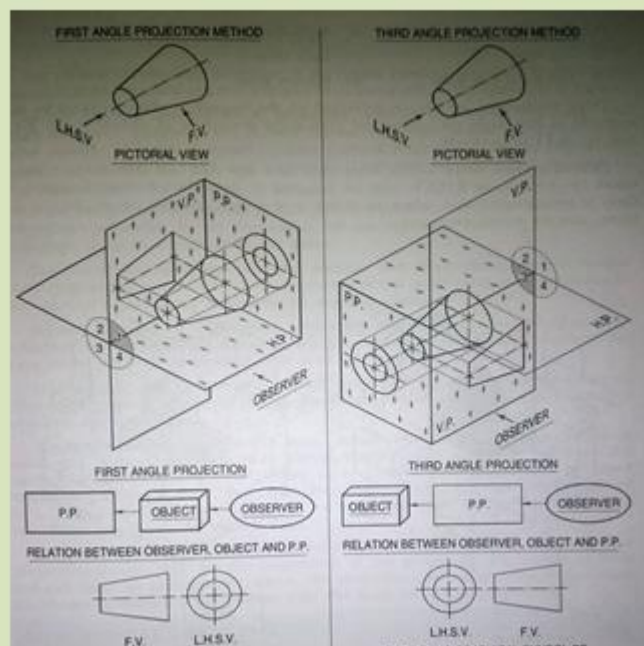

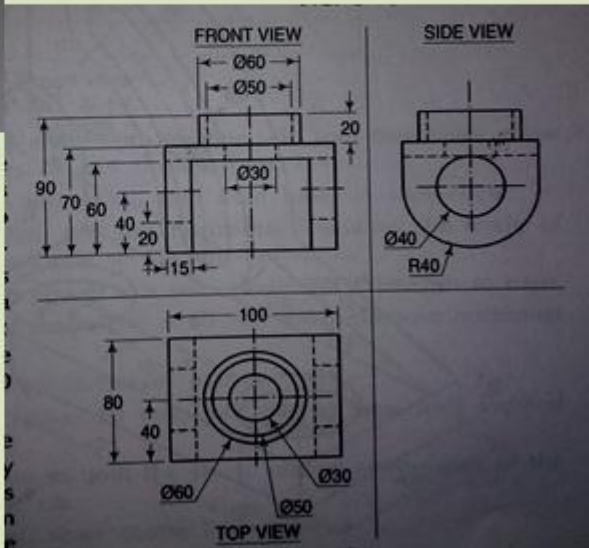
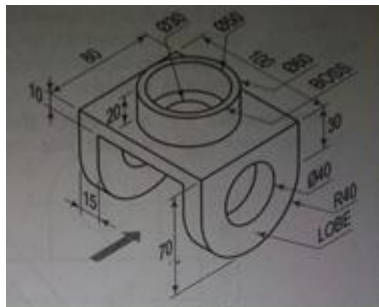
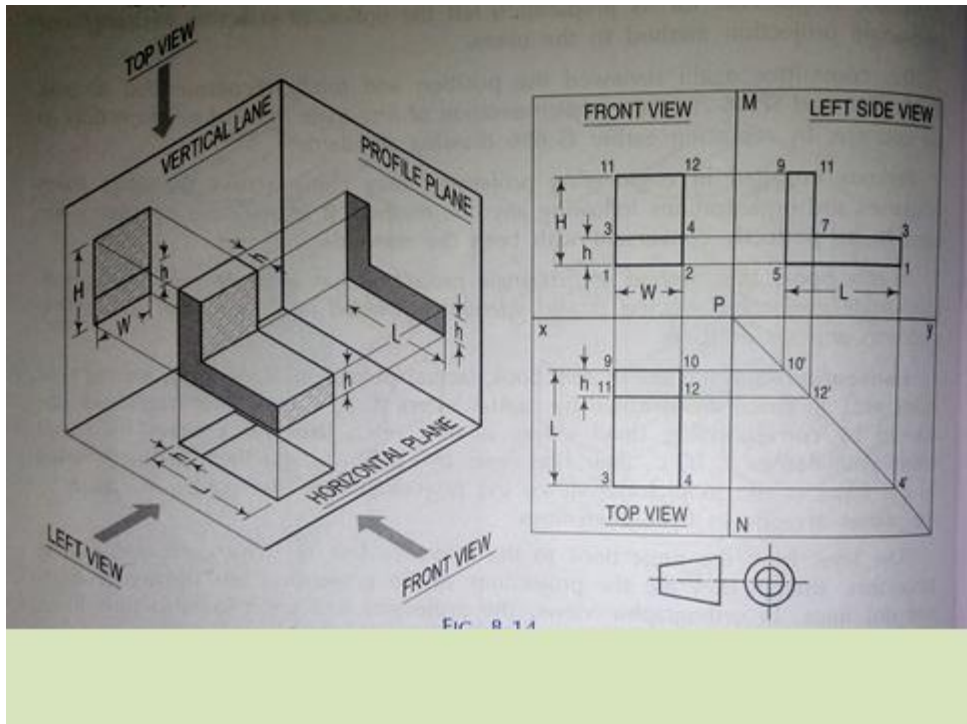

Point in 1st Quadrant

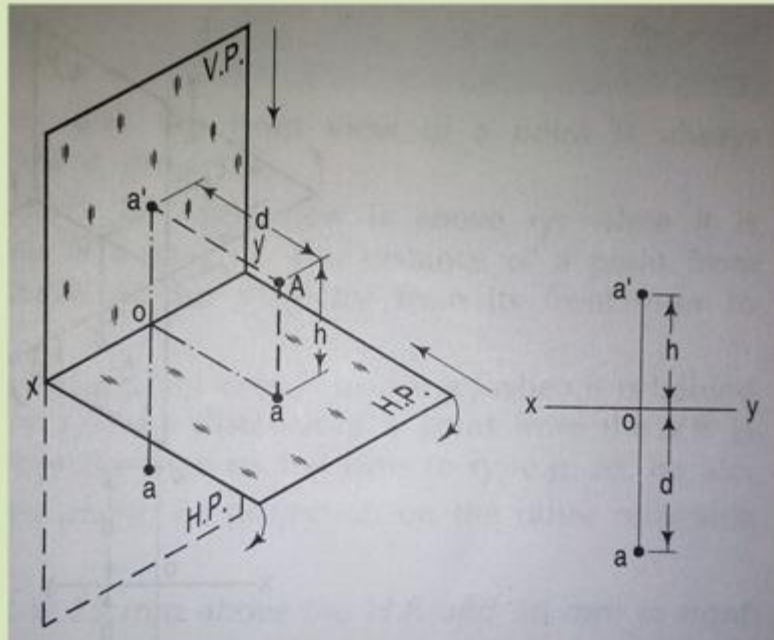

Point in 2nd Quadrant

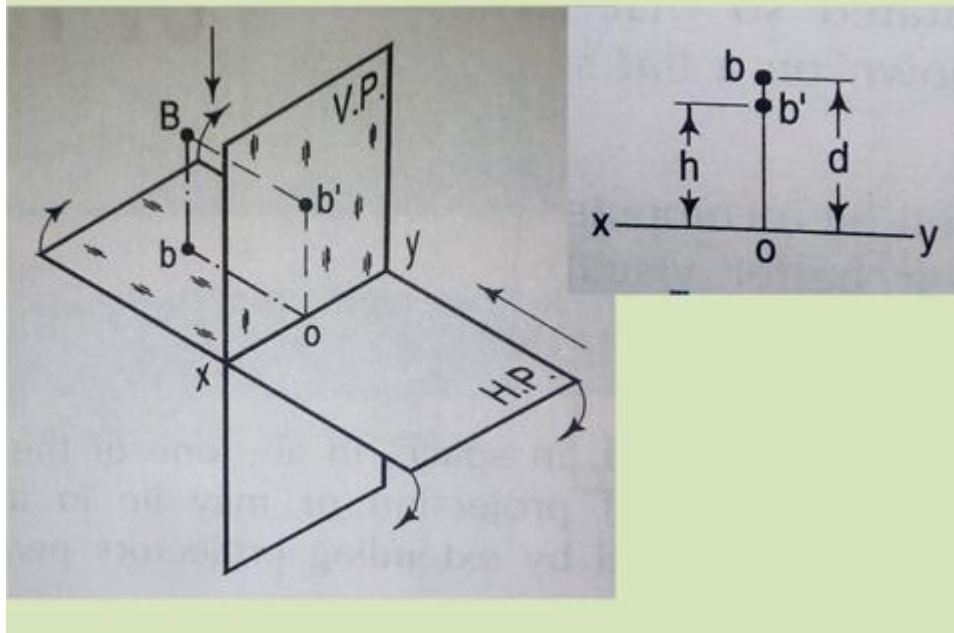

Point in 3rd Quadrant

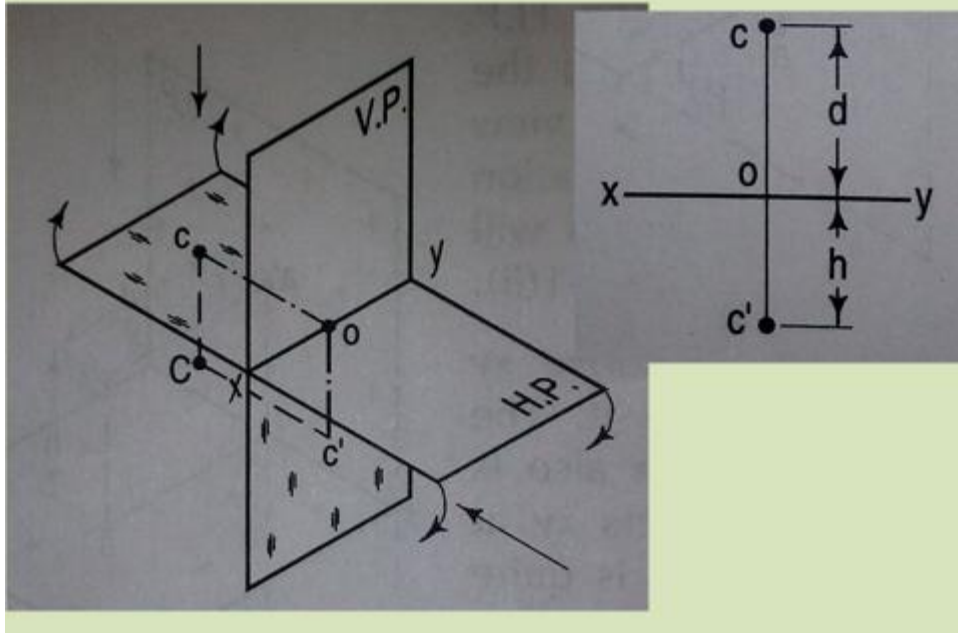

Point in 4th Quadrant

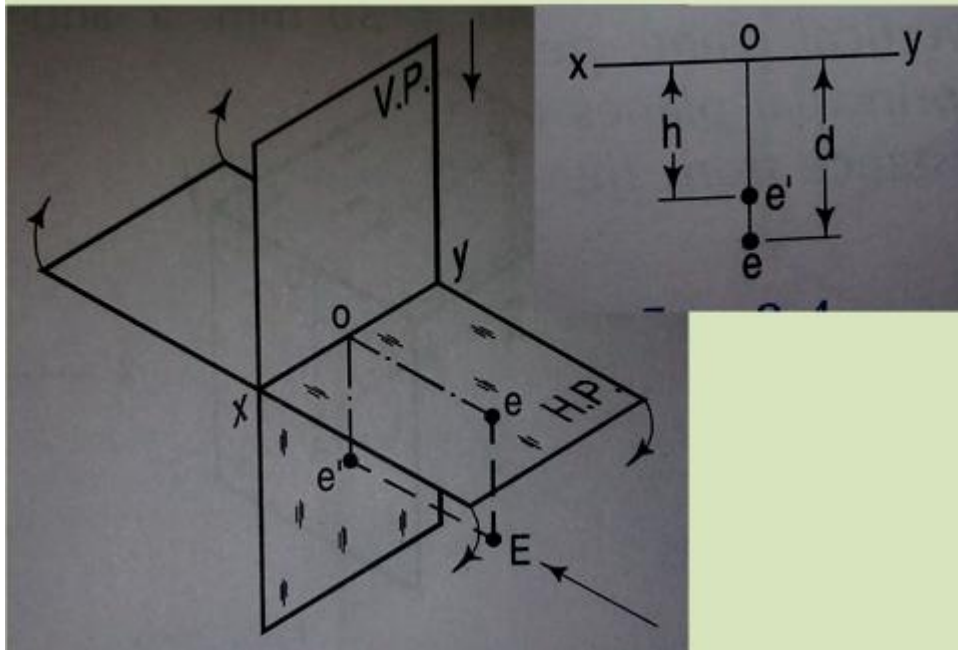

A point A is 20 mm below the H.P and 30 mm behind the V.P. Draw its projection

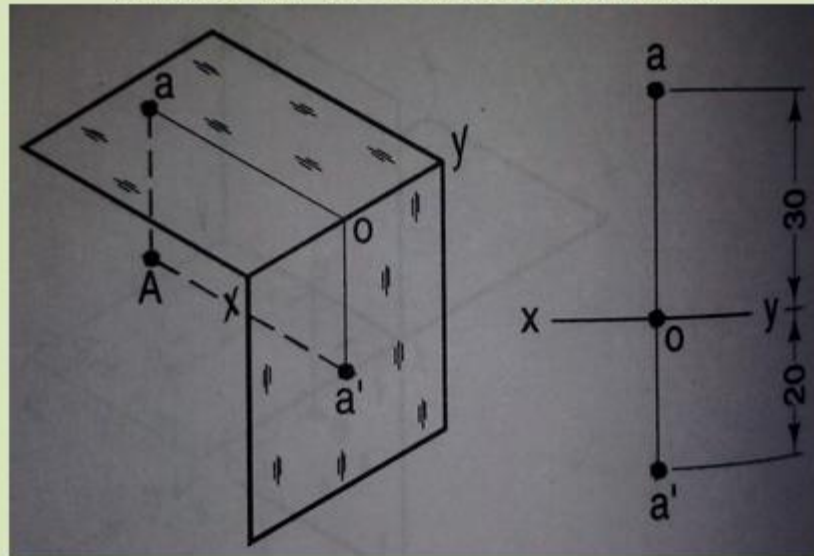

Sheet 3: Projection of points and lines:

1. Draw the projections of the following points on the same ground line, keeping the projections 25 mm apart.

- A) in the H.P and 20 mm behind the V.P
- B) 40 mm above the H.P and 25 mm in front of the V.P
- C) In the V.P and 40 mm above the H.P
- D) 25 mm below the H.P and 25 mm behind the V.P
- E) 15 mm above the H.P and 50 mm behind the V.P
- F) 40 mm below the H.P and 25 mm in front of the V.P
- G) In both the H.P and the V.P

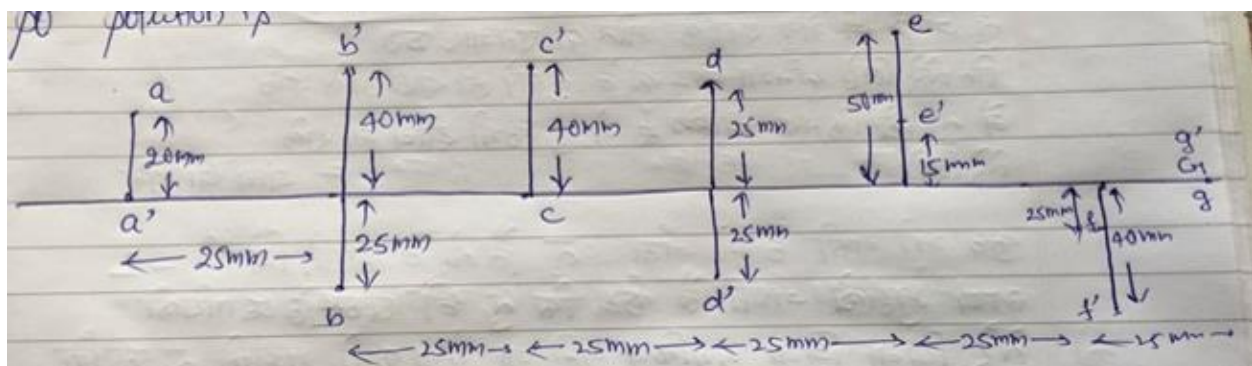

2. Draw the projections of a straight line of 75 mm long when it is 30° inclined to the H.P and 40° inclined to V.P Assume the end point A is 20 mm above the H.P and 30 mm in front of the V.P.
3. A line AB 65 mm long has its end A 20 mm above the H.P and 25 mm in front of the V.P the end B is 40 mm above the H.P and 65 mm in front of V.P.
4. A line AB is 90 mm long is inclined 30° to H.P. point A is 12 mm above the H.P and 20 mm in front of V.P. Its front view measured 65 mm Draw the top view of AB.

Projection of solids

Definition of Solid:

A solid is a three dimensional object having length, breadth and thickness. It is completely bounded by a surface or surfaces which may be curved or plane. The shape of the solid is described by drawing its two orthographic views usually on the two principle planes i.e. H.P and V.P. For some complicated solids, in addition to the above principle views, side view is also required. A solid is an aggregate of points, lines and planes and all problems on projections of solids would resolve themselves into projections of points, lines and planes.

Classification of Solids:

Solids may be divided into two main groups;

(A) Polyhedra: A Polyhedra is defined as a solid bounded by planes called faces which meet in straight lines called edges. There are seven regular Polyhedra which may be defined as stated below:

(1) Prism: It is a polyhedra having two equal and similar faces called its ends or bases, parallel to each other and joined by other rectangular faces. The imaginary line joining the centres of the bases or faces is called axis of prism.

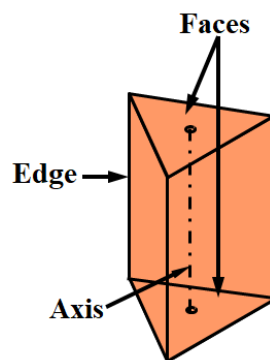

(2) Pyramid: This is a polyhedra having plane surface as a base and a number of triangular faces meeting at a point called the Vertex or Apex. The imaginary line joining the apex with the centre of the base is called axis of pyramid.

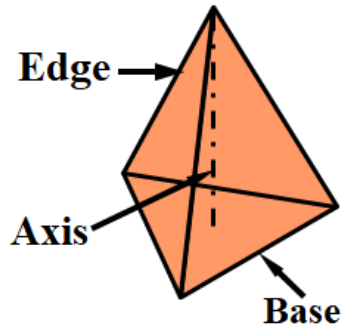

- (3) Tetrahedron: It has 4 equal faces, each an equilateral triangle.
- (4) Cube or Hexahedron: It has 6 equal faces, each a square.
- (5) Octahedron: It has 8 equal equilateral triangle faces.
- (6) Dodecahedron: It has 12 equal and regular pentagons as faces.
- (7) Icosahedron: It has 20 equal equilateral triangle faces.

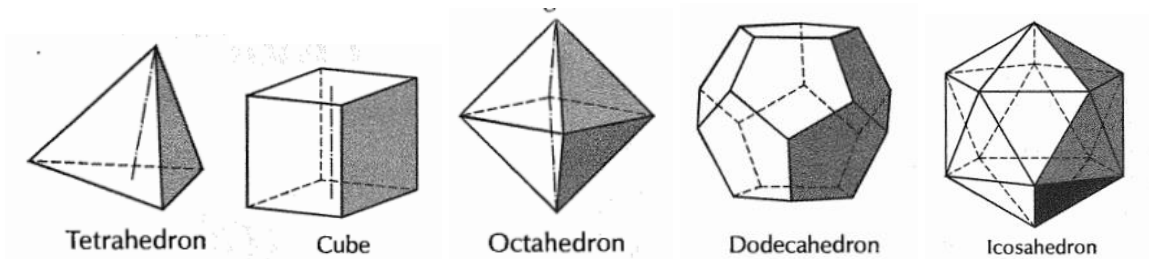

(B) Solids of revolution

When a solid is generated by revolutions of a plane figure about a fixed line (Axis) then such solids are named as solids of revolution.

Solids of revolutions may be of following types;

- (1) Cylinder: A right regular cylinder is a solid generated by the revolution of a rectangle about its vertical side which remains fixed.
- (2) Cone: A right circular cone is a solid generated by the revolution of a right angle triangle about its vertical side which remains fixed.

(3) Sphere: It is a solid generated by the revolution of a semi circle about its diameter as the axis

(4) Ellipsoid

(5) Paraboloid

(6) Hyperboloid

Some important terms generally used:

Right Solid: A solid is said to be a Right Solid if its axis is perpendicular to its base.

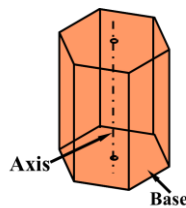

(2) Oblique Solid: A solid is said to be a Oblique Solid if its axis is inclined at an angle other than 90° to its base.

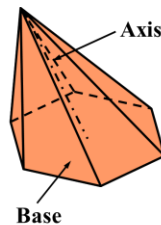

Sheet 4

1. Draw the projection of a cylinder, base 40 m diameter and axis 50 mm long resting on their respective bases.

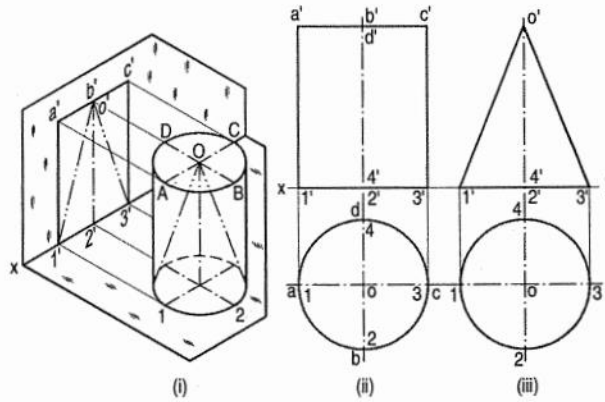

2. Draw the projection of a triangular prism, base 40 mm side and axis 50 mm long resting on one of its bases on H.P with vertical face perpendicular to the V.P.

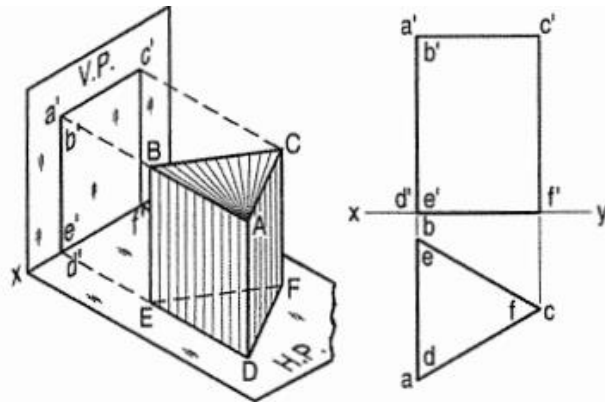

3. Draw the projection of a pentagonal pyramid, base 30 mm and axis 50 mm long, having its edge on H.P and base parallel to V.P.

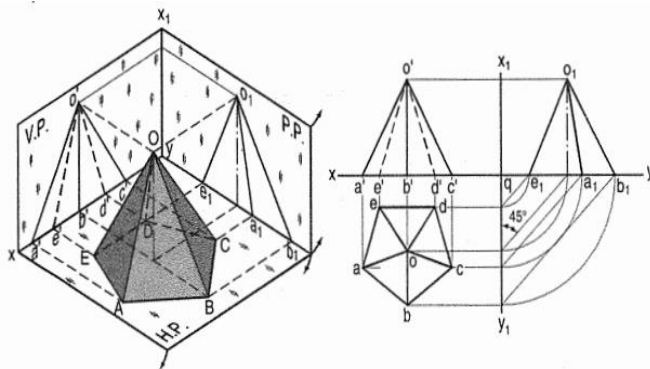

4. A hexagonal prism has one of its rectangular faces parallel to H.P its axis is perpendicular to V.P and 35 mm above the ground. Draw its projection when the nearer end is 20 mm in front of V.P side of base is 25 mm and axis is 50 mm long.

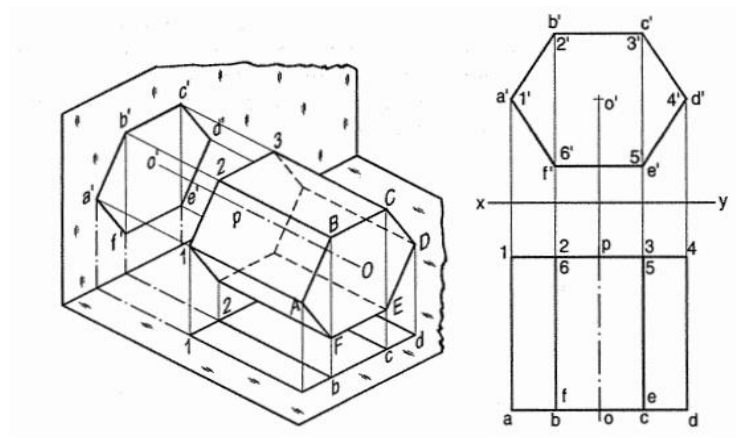

Section of solids

The internal hidden details of the object are shown in orthographic views by dashed lines. The intensity of dashed lines in orthographic views depends on the complexity of internal structure of the object. If there are many hidden lines, it is difficult to visualize the shape of the object unnecessarily complicated and confusing. Therefore, the general practice is to draw sectional views for complex objects in addition to or instead of simple orthographic views. A sectional view, as the name suggests, is obtained by taking the section of the object along a particular plane. An imaginary cutting plane is used to obtain the section of the object.

In engineering industries, when the internal structure of an object is complicated, it is very difficult to visualize the object from its orthographic views since there will be several hidden lines. In such case, the internal details are shown by sectional views. Sectional views are an important aspect of design and documentation since it is used to improve clarity and reveal interior features of parts.

Full Section View

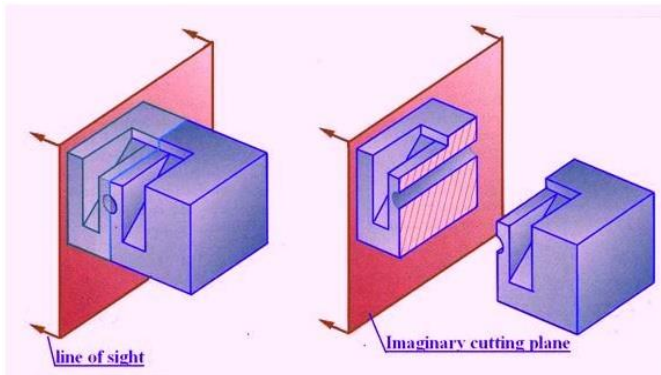

Half Section View

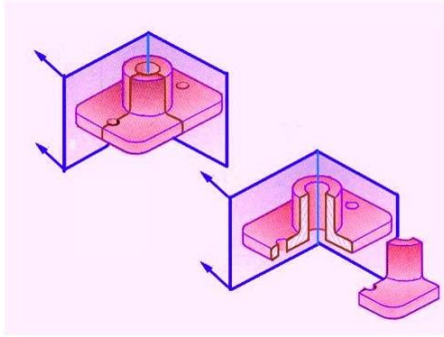

Offset Section View

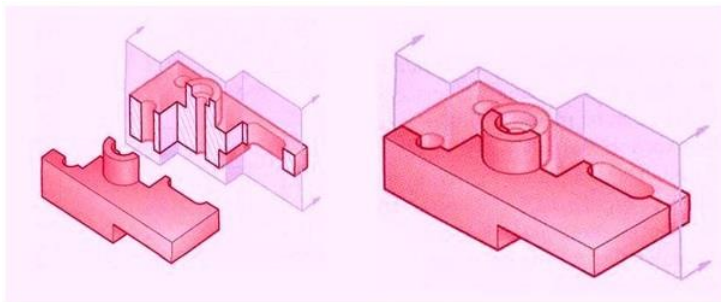

Cutting Plane Symbol

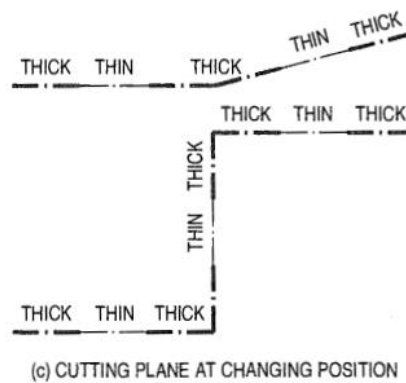
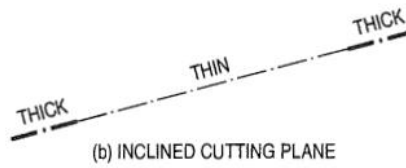
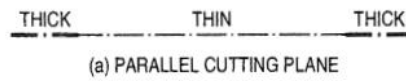

True Shape of Sections

A section will show its true shape when viewed in normal direction. To find the true shape of a section, it must be projected on a plane parallel to the section plane. For polyhedra, the true shape of the section depends on the number of POIs. The shape of the section will be a polygon of the sides equal to the number of POIs. The true shape of the section of a sphere is always a circle. The sections of prisms and pyramids are straight line segmented curves. The sections of cylinders and cones will mostly have smooth curves.

Hatching of the Sections

The surface created by cutting the object by a section plane is called as section. The section is indicated by drawing the hatching lines (section lines) within the sectioned area. The hatching lines are drawn at 45° to the principal outlines or the lines of symmetry of the section. The spacing between hatching lines should be uniform and in proportion to the size of the section.

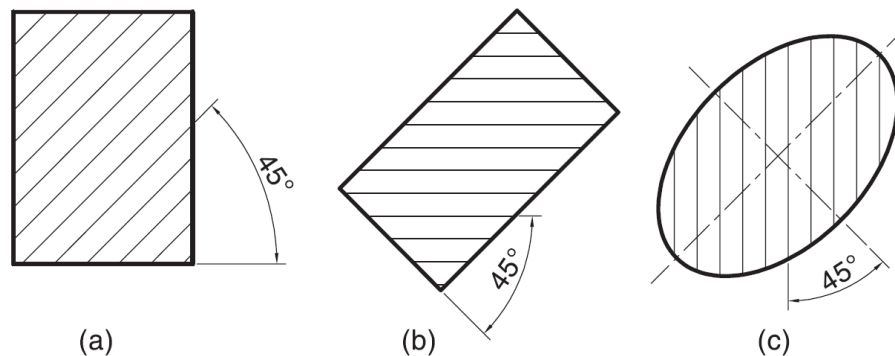

Sheet 5

1. A cylinder of 40 mm, 60 mm length and having its axis vertical in cut by a section plane, perpendicular to the V.P inclined at 45° to the H.P and intersecting the axis 32 mm above the base. Draw its front view, sectional top view and true shape of section.

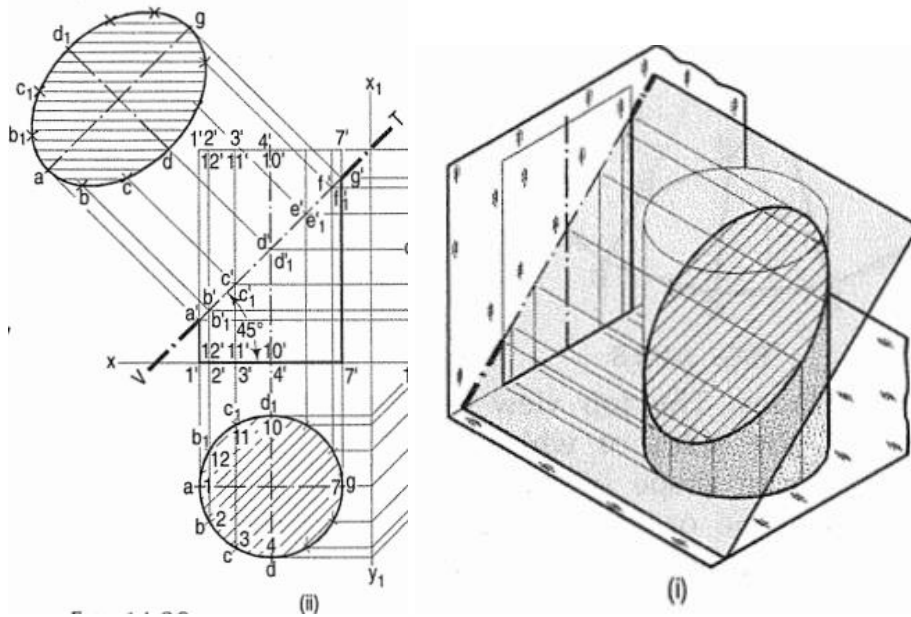

2. A square prism base 40 mm side and height 80 mm has its base on the H.P and its faces equally inclined to the V.P. it is cut by a plane perpendicular to V.P, inclined 60° the H.P and passing through the point on the axis 55 mm above the H.P. draw its front view, sectional top view and true shape of section.

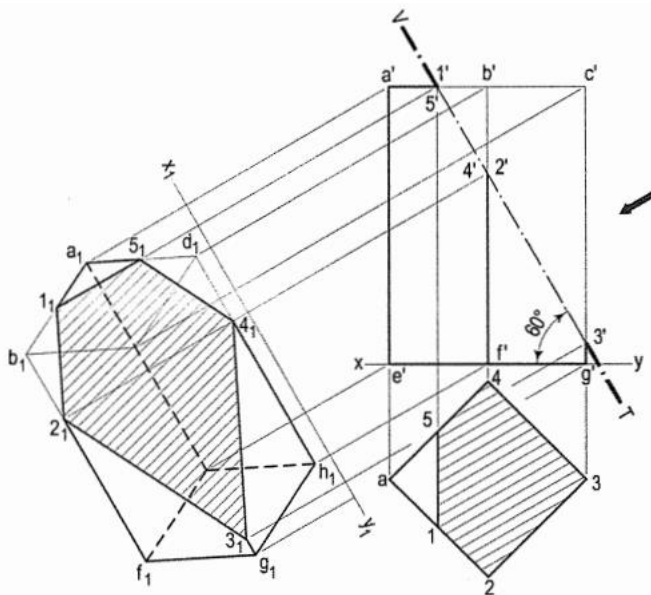

Problem 3: A cone, diameter of base 50 mm and axis 50 mm long is resting on its base on the H.P. It is cut by a section plane perpendicular to the V.P., inclined at 75° to the H.P. and passing through the apex. Draw its front view, sectional top view and true shape of the section.

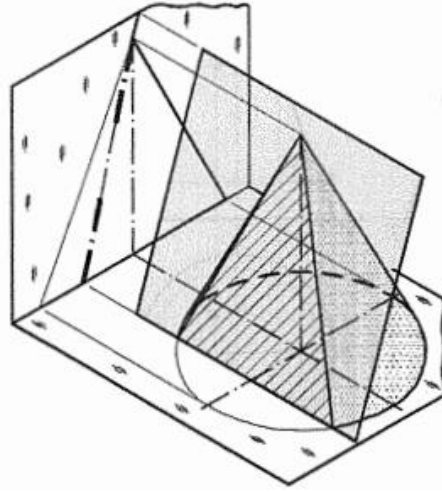
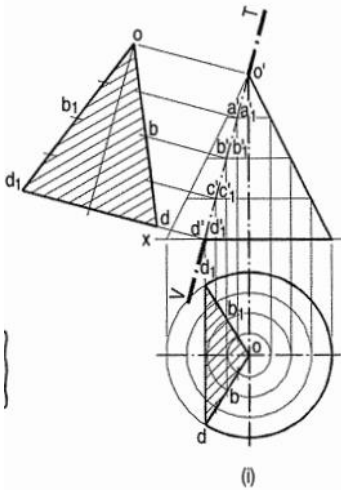

Development of surfaces

Some objects are made of flat sheet metal. When the sheet is cut as per this layout, folded and joined together, it takes the shape of an object.

Applications:

The knowledge of development of surfaces is very useful in sheet metal industry where products like utensils, cans, buckets, hoppers, domes etc. are manufactured.

The shape of a refrigerator is made from the sheet metal. Its door is first made on a plain sheet and then cut and folded to form the door.

Development should be such as to allow the minimum waste of material when the shape is cut out.

Development is a graphical method of obtaining the area of the surfaces of a solid. When a solid is opened out and its complete surface is laid on a plane, the surface of the solid is said to be developed. The figure thus obtained is called a development of the surfaces of the solid or simply development. Development of the solid, when folded or rolled, gives the solid.

Examples

Prism – Made up of same number of rectangles as sides of the base

One side: Height of the prism

Other side: Side of the base

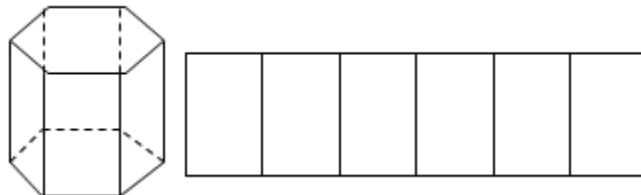

Cylinder – Rectangle

One side: Circumference of the base

Other side: Height of the cylinder



Pyramid – Number of triangles in contact

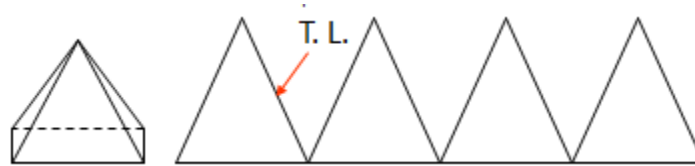

Development of cylinder:

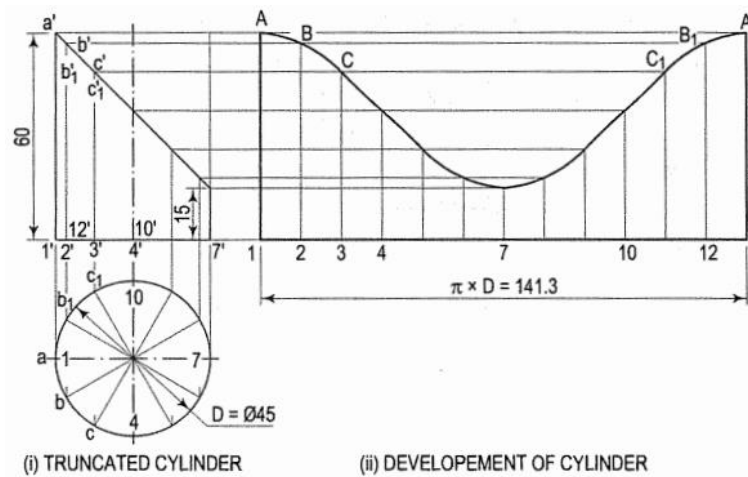

Sheet 6

1. A pentagonal prism base 20 mm side and axis 40 mm, resting with its base on the H.P and one edge of the base is parallel to and away from V.P. it is cut by a section plane perpendicular to the V.P and inclined at 45° to the H.P and bisecting the axis. Draw its development.

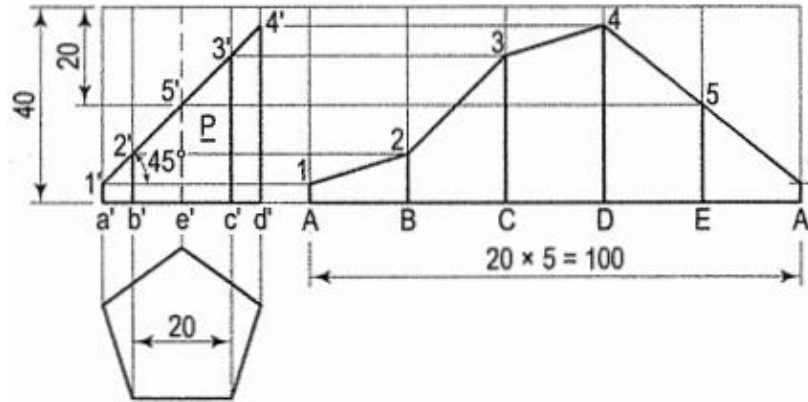

2. A cylinder base 50 mm dia, axis 60 mm long is resting with its base on H.P. it is cut by a section plane but by V.P and inclined at 45° to the H.P and intersecting the axis at a point 15 mm from the top of the axis. Draw its development.
3. Draw the development of internal surface of part P of hexagonal prism whose front view is shown in the fig.

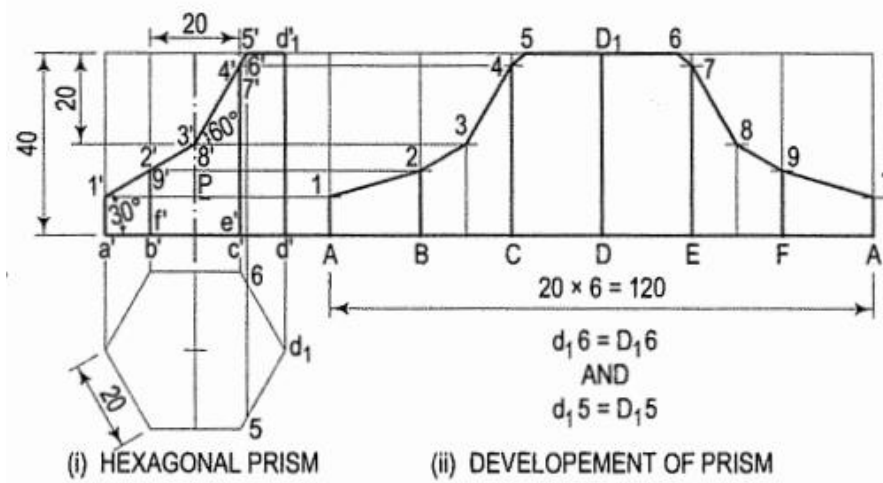

Isometric Projection

Isometric Projection of a cube

The three lines CB , CD and CG meeting at C and representing the three edges of the solid right-angle are also equally inclined to the V.P. and are therefore, equally foreshortened. They make equal angles of 120° with each other. The line CG being vertical, the other two lines CB and CD make 30° angle each, with the horizontal.

All the other lines representing the edges of the cube are parallel to one or the other of the above three lines and are also equally foreshortened.

The diagonal BD of the top face is parallel to the V.P. and hence, retains its true length.

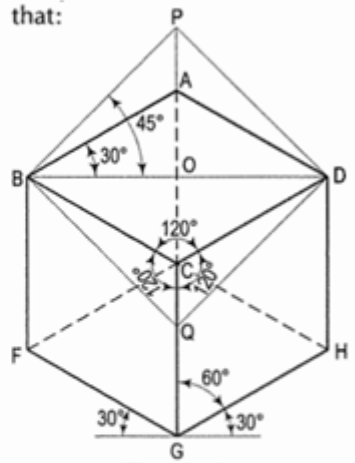

17-2. ISOMETRIC AXES, LINES AND PLANES

The three lines CB , CD and CG meeting at the point C and making 120° angles with each other are termed *isometric axes*. The lines parallel to these axes are called *isometric lines*. The planes representing the faces of the cube as well as other planes parallel to these planes are called *isometric planes*.

Isometric Scale

As all the edges of the cube are equally foreshortened, the square faces are seen as rhombuses. The rhombus $ABCD$ (fig. 17-2) shows the isometric projection of the top square face of the cube in which BD is the true length of the diagonal.

Construct a square $BQDP$ around BD as a diagonal. Then BP shows the true length of BA .

$$\text{In triangle } ABO, \frac{BA}{BO} = \frac{1}{\cos 30^\circ} = \frac{2}{\sqrt{3}}$$

$$\text{In triangle } PBO, \frac{BP}{BO} = \frac{1}{\cos 45^\circ} = \frac{\sqrt{2}}{1}$$

$$\frac{BA}{BP} = \frac{2}{\sqrt{3}} \times \frac{1}{\sqrt{2}} = \frac{\sqrt{2}}{\sqrt{3}} = 0.815$$

$$\text{The ratio, } \frac{\text{isometric length}}{\text{true length}} = \frac{BA}{BP} = \frac{\sqrt{2}}{\sqrt{3}} = 0.815 \text{ or } \frac{9}{11} \text{ (approx.).}$$

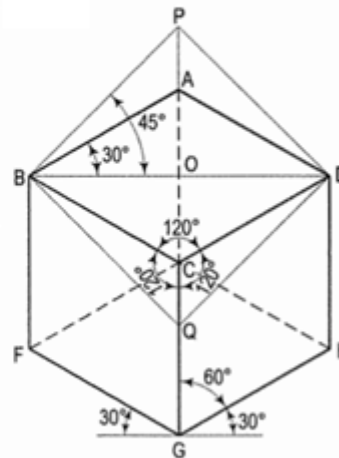
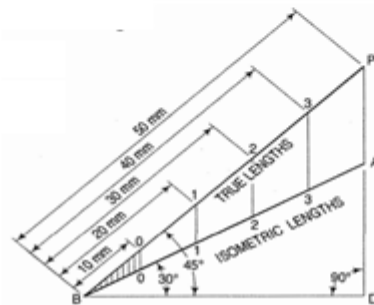

Isometric projection vs. Isometric view

- If the foreshortening of the isometric lines in an isometric projection is disregarded and instead, the true lengths are marked, then it is called isometric view. It has become a general practice to use the true scale instead of the isometric scale.
- To avoid confusion, the view drawn with true scale is called isometric drawing or isometric view, while that drawn with the use of isometric scale is called isometric projection.

Sheet 7

Problem 1: Draw the isometric view of a square prism, side of the base 20 mm long and the axis 40 mm long, when its axis is (i) vertical and (ii) horizontal.

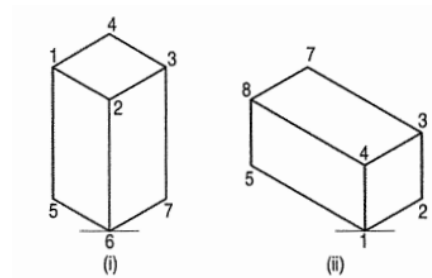

Problem 2: Draw the isometric view of the model of steps, two views of which are shown as below.

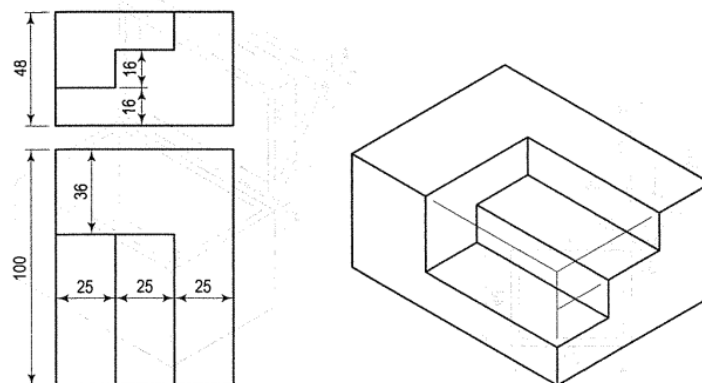

Problem 3: The orthographic projections of the object are shown in figure as below. Draw the isometric view of the object.

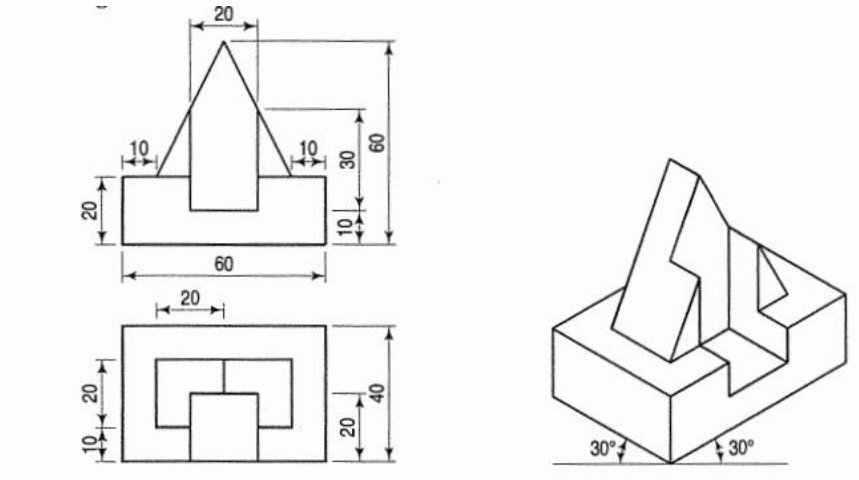

AUTO CAD

Sheet 1

